

## Introduction

Diaphragm Valves proved to be the answer to many process engineers' greatest desire of reliability at an acceptable cost of ownership. Of simple and reliable design, diaphragm valves offer secure operation with full leaktight at the plant. The maintenance, when required, is limited to the replacement of the diaphragm, the bolted bonnet design permits to dismantle the valve without removing the valve body from the pipe work.

The body seatless design eases the internal lining, which opens a broad range to inexpensive options to process engineers when selecting materials resistant to corrosion and abrasion duties. Conventional isolating valves would demand expensive exotic materials to resist the effects of severe corrosion whereas a duly lined iron based material can do the job.

**DIAVAL** portfolio clearly meets the requirements of modern industrial processes and the needs of all engineers. Through constant product development and own polymer research technology, **DIAVAL®** Diaphragm Valves are a reliable alternative to existing costly and expensive to maintain conventional valves.

**DIAVAL INTERNATIONAL** manufacture one of the largest Diaphragm Valves portfolio comprehensive of body linings, diaphragm grades and actuation currently available in the international market. Your **DIAVAL®** Team is available to guide you along a great cost saving experience.



**DIAVAL®** range of superior design and major cost saving benefits, for secure and full leaktight operation under the most severe circumstances.

The **DIAVAL®** range is totally interchangeable with other diaphragm valves in the market thus easing the plant choice.

# **Valve stroke Indicator**; a yellow position indicator gives clear and positive valve position from any angle.

# **Greased for life valve spindle**; spindle chamber incorporates a grease reservoir that lubricates the spindle along operations thus avoiding valve spindle jamming. Sealed bonnet arrangements available for toxic and hazardous fluids.

# **Valve stroke stopper**; the bonnet design prevents over closure of the valve thus avoiding early diaphragm rupture.

# **Ergonomically Design Hand wheel**; great comfort and ease of operation. Other operation options such as actuators, padlocks, interlocking, extended spindle and others are available from **DIAVAL®**.

# **Self draining**; Weir valves are self draining when installed at an angle of 20° above horizontal. ST and Full Flow valves are self cleaning with an unobstructed bore.

# **Diaphragms**; wide range of diaphragm materials to meet the needs of today's industrial processes and standards. Resilient diaphragms provides 100% leak-tight shut off and isolates all bonnet parts from the line fluid.

# **Safety**; Optional Sealed bonnet arrangements available for toxic and hazardous fluids, Interlocking arrangement, padlocking and flange sealing coating.

# **Linings**; porous free chemically resistant linings designed to eliminate the need of expensive metals. Wide range of polymers and fluoropolymers available to match all industrial needs. Full face rubber lining removes the need for gaskets unlike spigot face lining.

# **Body end connections**; flanged and screwed ends to meet all European, Imperial and American standards. Other end styles available for the aseptic range.

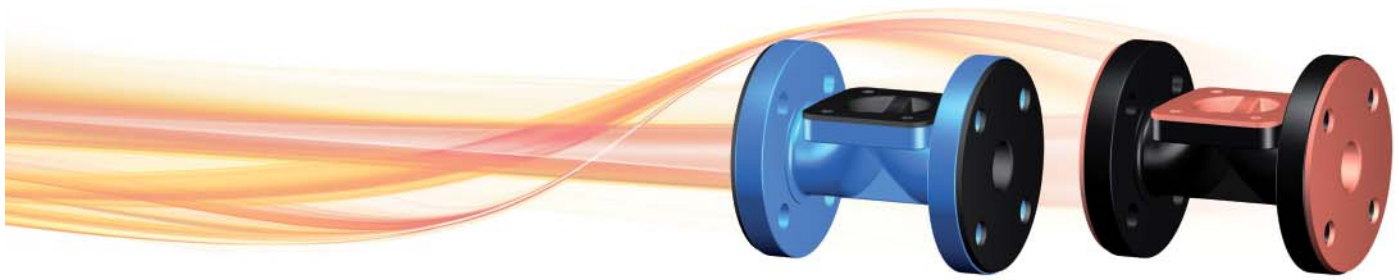

## Application Guide - Lining

Lining Material	Applications
<b>Hard Rubber - HR</b> (Ebonite), sulphur cured, carbon black reinforced. Designated by a 'Sky Blue Spot' on end flange.	Used for inorganic salt solutions, dilute mineral acids, chlorine water, deionised and potable water.
<b>Soft Natural Rubber-SR</b> Polyisoprene, sulphur cured, carbon black reinforced. Designated by a 'white spot' on end flange.	Excellent abrasion resistance for powders, slurries such as clays, fly ash and cement products.
<b>Soft Butyl Rubber-BR</b> Isobutylene isoprene (IIR), sulphur cured carbon black reinforced. Designated by a 'Dark Blue Spot' on end flange.	Good for corrosive and abrasive slurries, dilute mineral acids and acidic slurries. Avoid chlorine and chlorine solutions.
<b>Soft Polychloroprene (Neoprene) Rubber</b> Non-Sulphur cured carbon black reinforced. Designated by a 'Red Spot' on end flange. Hardness 65- +/- 5° Shore 'A'	Used on abrasives and minerals processing where small percentages of hydrocarbons are present.
<b>Soft Hypalon® Rubber - (Chloro sulphonated polyethylene)</b> Non-Sulphur cured carbon black reinforced. Designated by a 'Green Spot' on the end flange.	Chemical resistance to dilute / medium strength acids and chlorinated brine solutions and sodium hypochlorite
<b>Linatex®</b> Specially compounded "RED" coloured soft lining Hardness 45 +/- 5° Shore 'A'	Used for "WET" slurry applications

### Speciality lining material for specific service

<b>Halar®</b> Co-polymer of ethylene and chlorotrifluoroethylene. Electrostatically applied coating.	Used for concentrated acids and salts containing hydrocarbons. Not suitable for dilute acids and inorganic salt solutions near to their boiling point. Minimal resistance to abrasive services.
<b>Polytetrafluoro alkoxy-PFA®</b> . Natural colour.	Most suitable for concentrated mineral acids at high temperature, aromatic and aliphatic and chlorinated solvents.
<b>Ethylene tetrafluoroethylene-ET-FE®</b> . Natural colour.	Most suitable for concentrated mineral acids at high temperature, aromatic and aliphatic and chlorinated solvents
<b>FEP &amp; PVDF</b>	Consult Diaval@ (DN 350 under special manufacture)

## Design Attributes

Straight Through Type Diaphragm Valves are linear motion valves, bidirectional, for stopping the flow of the service fluid when necessary, not being suitable for regulation purposes. Valves close by turning the handwheel clockwise. Valves are bolted bonnet, seatless design, with a diaphragm as closure element, with rising handwheel. Valves are offered with a broad range of diaphragms and linings materials to resist to abrasion and corrosion duties. Their straight passage makes them more suitable for on/off applications in comparison to Weir Type, when low pressure drop is required or in case of abrasive media. The valves are inexpensive and easy to maintain, being the optimal solution for a large number of applications.

Yellow position indicator, for clear and positive valve position from any angle

Ergonomic and rugged rising handwheel

Grease reservoir integrated in the spindle chamber that lubricates the spindle along operations thus avoiding valve spindle jamming

Nameplate incl. batch no. for full traceability

Witness hole to detect leakage at diaphragm failure

Precise compressor plate; guides and operates the diaphragm up and down

Closure Diaphragms; manufactured from elastomeric materials; provide 100% seating tightness in both directions while isolating the valve trim from fluid. Wide choice of polymers to satisfy any industrial application

Full rubber flange face in all rubber lined valves as standard

Porousless linings; provides the application engineer with a wide choice of linings of high chemical and abrasion resistance without need of expensive basic metal valve materials

Pocketless design, unobstructed bore

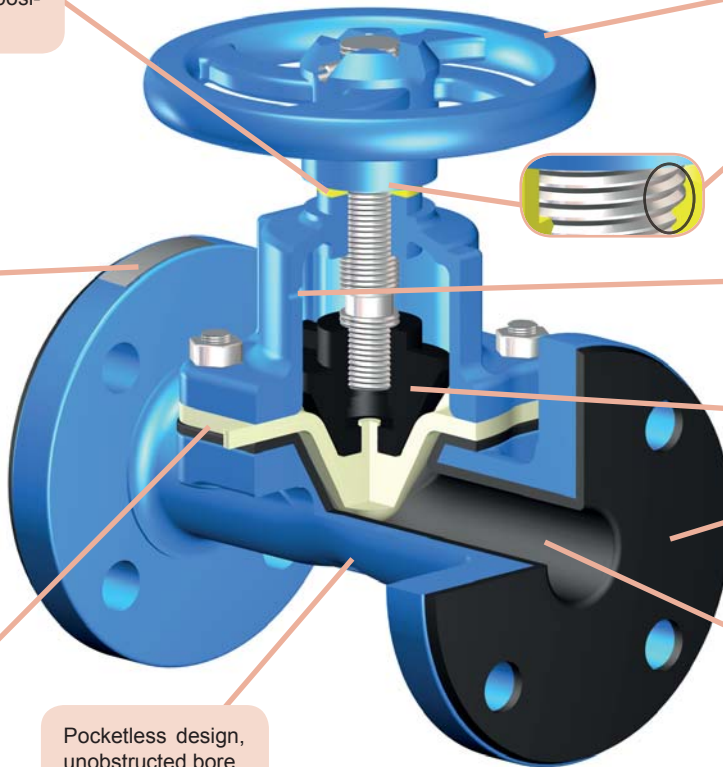

## Main Features

Valve design: EN 13397, EN 12516

Face to face length: EN 558 Series 1 (DIN 3202F1) or EN 558 Series 7 (BS 5156)

Valve end connections: Flanged to EN 1092-2 type 21/B, PN10/16 (DN15-150); PN10 (DN200-300)

(valves DN65 with 4 holes as accepted variant in standard)

option drilling to ASA150#

Female thread to ISO 228-1 (DIN 259-BSPP)

Marking: EN 19

Pressure Tests: EN 12266-1

Seat leakage rate: Rate A (full seat tightness in both directions)

Inside and outside primer paint layer black color for protection during storage and transport

Product compliant with Directive 2014/68/EU on Pressure Equipment (PED) and Machinery Directive 2006/42/EC

## Options

Other materials, other ratings and connections, pneumatic or electric actuator, limit switches, sealed bonnet, interlocking arrangement, padlocking or handwheel hood to avoid non-authorized operation. Please consult us

## Rubber lined valves with flanged ends

### Main Parts and Materials

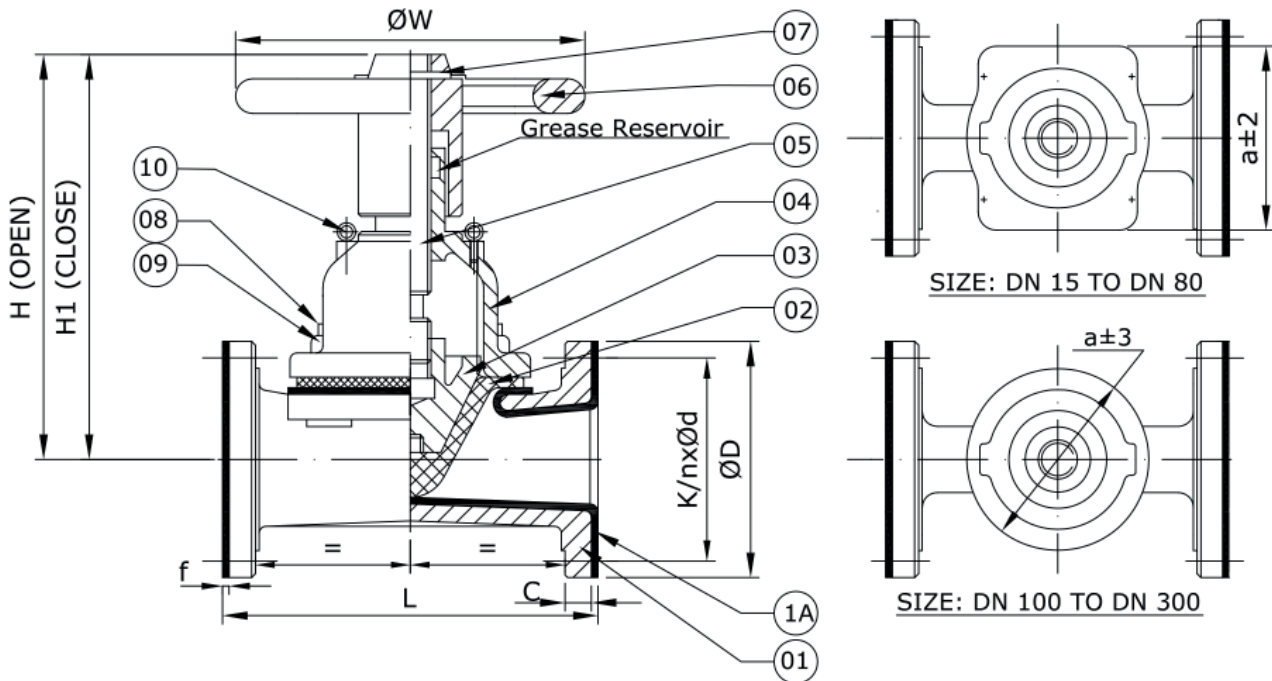

NO.	PART	MATERIAL
1	BODY	SC_ Cast iron EN-JL1040 (GG25)
		SD_ Ductile iron EN-JS1030 (GGG40)
1A	LINING	_HR_ Hard rubber
		_SR_ Soft rubber
		_BR_ Butyl rubber
		_ER_ EPDM rubber
		_NL_ Neoprene rubber
2	DIAPHRAGM	Rubber Natural (D10) / EPDM (D20) / Butyl (D30) / Nitrile (D40) / Neoprene (D50) / Hypalon (D60) / Viton (D70)

NO.	PART	MATERIAL
3	COMPRESSOR	Cast iron EN-JL1040 (GG25)
4	BONNET	SC_ Cast iron EN-JL1040 (GG25)
		SD_ Ductile iron EN-JS1030 (GGG40)
5	SPINDLE	Steel
6	HANDWHEEL	Cast iron EN-JL1040 (GG25)
7	H/W DOWEL PIN	Steel (EN42)
8	BODY STUDS	Steel
9	BODY NUTS	Steel
10	EYE BOLT*	Steel

\* Only for some sizes

### Main Valve Parameters

	DN	15	20	25	32	40	50	65
L	EN 558 S7 (BS 5156)	114	123	133	152	165	196	222
	EN 558 S1 (DIN 3202 F1)	130	150	160	180	200	230	290
	H (open)	113	111	135,5	133,5	134,5	197,5	223
	H1 (close)	105	103	123	121	122	180	199
	f	3	3	3	3	3	3	3
	a	71	71	85	85	85	115	130
FLANGED ENDS TO EN PN10	ØW	100	100	120	120	120	164	220
	ØD	95	105	115	140	150	165	185
	C	14	16	16	18	18	20	20
	nxØd	4x14	4x14	4x14	4x18	4x18	4x18	4x18
	ØK	65	75	85	100	110	125	145
FLANGED ENDS TO ASA150#	ØD	89	98	108	117	127	152	178
	C	11,5	11,5	11,5	13,0	14,5	16,0	17,5
	nxØd	4x16	4x16	4x16	4x16	4x16	4x19	4x19
	ØK	60,3	69,8	79,4	88,9	98,4	120,6	139,7
Approx. Weight	EN 558 S7 (BS 5156)	3,6	4	4,5	7	8	12	17
	EN 558 S1 (DIN 3202 F1)	4,1	4,5	5,0	8	9	13,5	18

\*Unless specific agreement with COMEVAL, valves with flanges 150# will be usually supplied as EN/DIN flanges with 150# drilling, since pressure is limited to EN/DIN

Dimensions in mm subject to manufacturing tolerance / Weights in kg

Information / restriction of technical rules need to be observed!  
Installation, Operating and Maintenance Manual can be downloaded at [www.comeval.es](http://www.comeval.es)

The engineer, designing a system or a plant, is responsible for the selection of the correct valve  
Product suitability must be verified, contact manufacturer for information

## Rubber lined valves with flanged ends

### Main Valve Parameters

	DN	80	100	125	150	200	250	300
<b>L</b>	<b>EN 558 S7 (BS 5156)</b>	260	313	364	414	529	643	757
	<b>EN 558 S1 (DIN 3202 F1)</b>	310	350	400	480	600	730	850
	<b>H (open)</b>	282	297,5	313,5	417	479,5	598,5	752
	<b>H1 (close)</b>	252	265	276	366	417	527	657
	<b>f</b>	3	4	4	4	4	4	4
	<b>a</b>	171	Ø200	Ø234	Ø290	Ø350	Ø430	Ø512
	<b>ØW</b>	240	270	270	360	460	525	600
<b>FLANGED ENDS TO EN PN10</b>	<b>ØD</b>	200	220	250	285	340	395	445
	<b>C</b>	22	24	26	26	26	28	28
	<b>nxØd</b>	8x18	8x18	8x18	8x22	8x22	12x22	12x22
	<b>ØK</b>	160	180	210	240	295	350	400
<b>FLANGED ENDS TO ASA150#*</b>	<b>ØD</b>	191	229	254	279	343	406	483
	<b>C</b>	19,5	24,0	24,0	25,5	29,0	30,5	32,0
	<b>nxØd</b>	4x19	8x19	8x22	8x22	8x22	12x26	12x26
	<b>ØK</b>	152,4	190,5	215,9	241,3	298,4	361,9	431,8
<b>Approx. Weight</b>	<b>EN 558 S7 (BS 5156)</b>	24	32	46	65	115	175	263
	<b>EN 558 S1 (DIN 3202 F1)</b>	27	34	48	71	121	190	278

\*Unless specific agreement with COMEVAL, valves with flanges 150# will be usually supplied as EN/DIN flanges with 150# drilling, since pressure is limited to EN/DIN

Dimensions in mm subject to manufacturing tolerance / Weights in kg